

## Technische Abmessungen

Wir weisen ausdrücklich darauf hin, dass alle Angaben ohne Gewähr sind !

# DIN 6332 Gewindestifte mit Druckzapfen, SK = mit Innensechskant

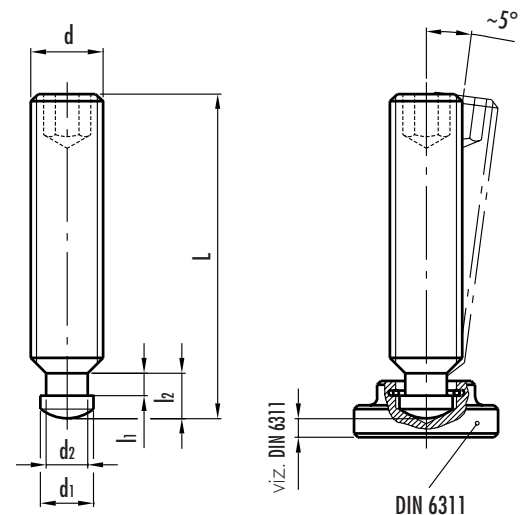

	d 6g	L	d1 h11	d2	l1	l2	g
M6		30	4.5	4	2.9	5.4	5
		35					6
		40					7
		45					8
		50					9
M8		35	6	5.4	3.8	6.8	11
		40					12
		45					13
		50					14
		60					17
		70					21
M10		45	8	7.2	3.7	8.2	21
		50					23
		55					25
		60					28
		65					30
		80					37
M12		50	8	7.2	4.1	8.6	32
		60					39
		65					42
		70					46
		80					53
		100					66
M16		65	12	11	5.6	10.6	65
		70					83
		75					90
		80					97
		100					121
		125					154
M20		80	15.5	14.4	6.9	12.4	149
		90					171
		100					189
		125					241
		150					292

	d 6g	L	d1 h11	d2	l1	l2	g
M6		30	4.5	4	2.9	5.4	5
		35					6
		40					7
		45					8
		50					9
M8		35	6	5.4	3.3	6.8	11
		40					12
		45					13
		50					14
		60					17
		70					21
M10		45	8	7.2	3.7	8.2	21
		50					23
		55					25
		60					28
		65					30
		80					37
M12		50	8	7.2	4.1	8.6	32
		60					39
		65					42
		70					46
		80					53
		100					66
M16		65	12	11	5.6	10.6	65
		70					83
		75					90
		80					97
		100					121
		125					154
M20		80	15.5	14.4	6.9	12.4	149
		90					171
		100					189
		125					241
		150					292